



Section 6

Dual Air  
Brake System

## Basic Dual Air Brake System

Most air brake equipped vehicles on the road today are using a dual air brake system. The system has been developed to accommodate a mechanically secured parking brake that can be applied in the event of service brake failure. It also accommodates the need for a modulated braking system should either one of the two systems fail. It is actually two brake systems in one, with more reservoir capacity resulting in a much safer system. At first glance, the dual system might seem complicated, but if you understand the basic air brake system described so far, and if the dual system

is separated into basic functions, it becomes quite simple.

As its name suggests, the dual system is two systems or circuits in one. There are different ways of separating the two parts of the system. On a two-axle vehicle, one circuit operates the rear axle and the other circuit operates the front axle. If one circuit has a failure, the other circuit is isolated and will continue to operate.

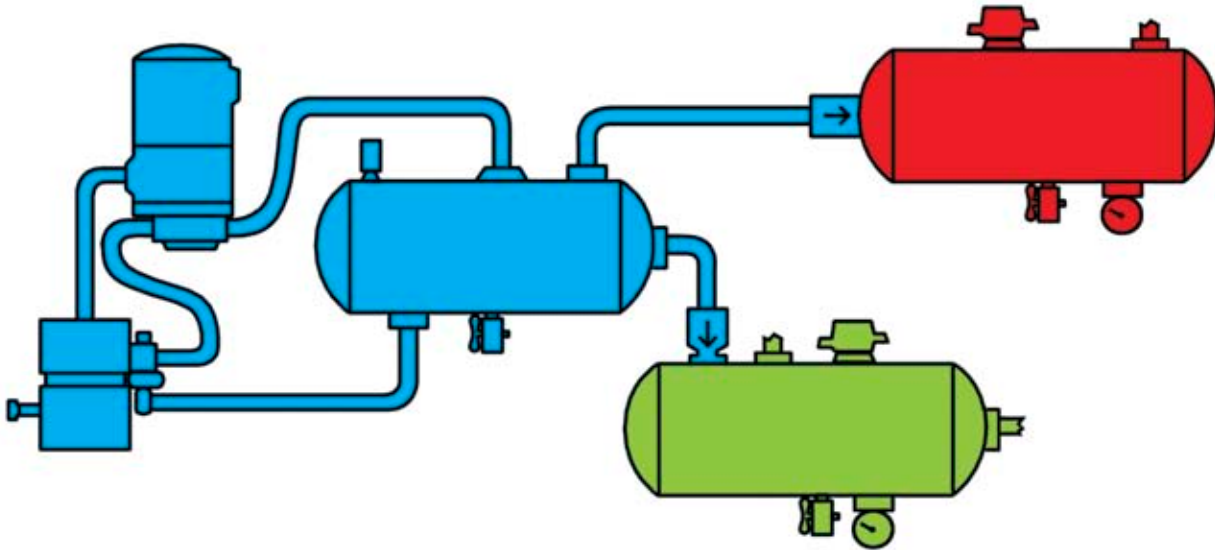

## Dual Air Brake System

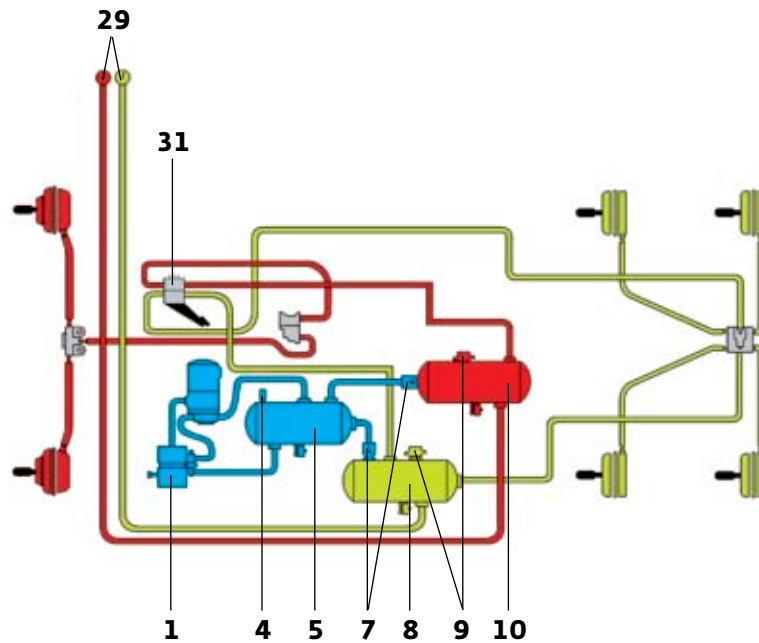

In the illustration, air is pumped by the compressor (1) to the supply/wet reservoir (5) (blue), which is protected from over pressurization by a safety valve (4). Pressurized air moves from the supply/wet reservoir to the primary/dry reservoir (8) (green) and the secondary/dry reservoir (10) (red) through one-way check valves (7). At this point, the dual circuits start. Air from the primary/dry reservoir is directed to the foot valve (31). Air is also directed from the secondary/dry reservoir to the foot valve. The foot valve is similar to the one described earlier in the basic air brake system, but is divided into two sections (two foot valves in one). One section of this dual foot valve controls the primary circuit and the other controls the secondary circuit. When a brake application is made, air is drawn from the primary reservoir through the foot valve and is passed on to the rear brake chambers. At the same time, air is also drawn from the secondary reservoir, passes through the foot valve and is passed on to the front brake chambers. If there is air loss in either circuit, the other will continue to operate independently. Unless air is lost in both circuits, the vehicle will continue to have braking ability. The primary and secondary circuits are equipped with low air pressure warning devices, which are triggered by the low air pressure indicator switch (9) and reservoir air pressure gauges (29) located on the dash of the vehicle.

## Dual-Circuit Foot Valve

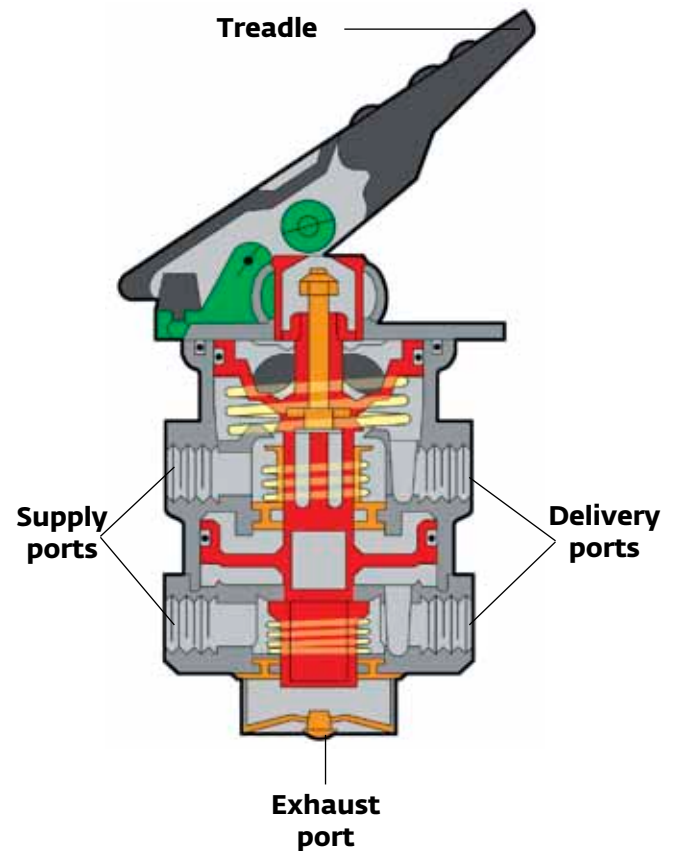

## Dual Air Brake System with Spring Parking Brakes

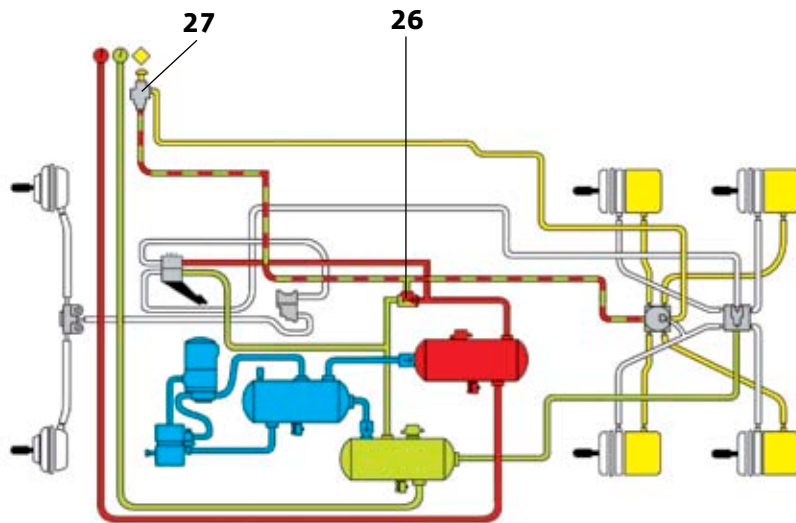

When spring brakes are added to a dual air brake system, the same type of dash control valve discussed previously is used. Blended air is used to supply the spring parking brake control valve (27). Blended air is air taken from the primary and secondary circuits

through a two-way check valve (26). With this piping arrangement the vehicle can have a failure in either circuit without the spring brakes applying automatically. If air is lost in both circuits, the spring brakes will apply.

## Spring Parking Brakes with Modulator Valve

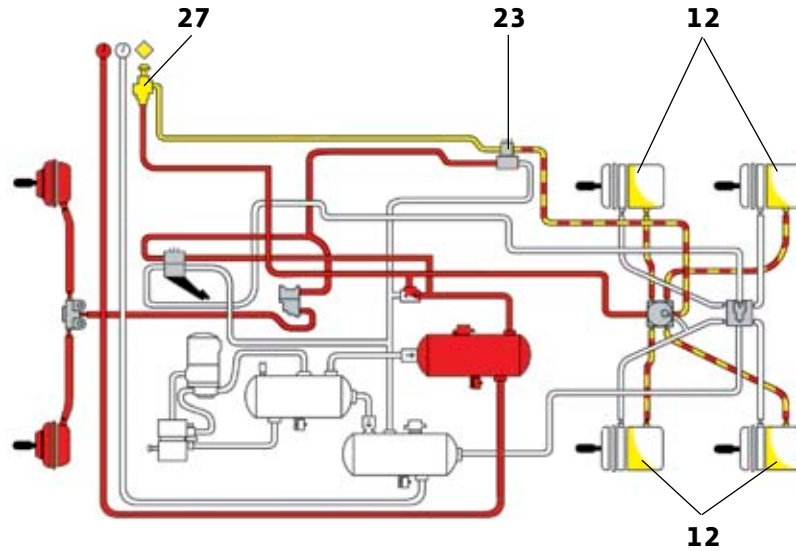

Spring parking brakes in this system serve two purposes: first, as a parking brake, and second as an emergency braking system. If a failure occurs in the primary circuit (green), and a brake application is made, control air from the foot valve is directed to a spring brake modulator valve (23). As there is no supply air to maintain balance in the modulator valve, because of the primary circuit failure, the modulator valve then exhausts air pressure from the spring parking brake circuit. The amount of air released is equal to the amount of air applied by the foot valve. The release of air in the spring parking brake circuit causes the drive axle to brake using spring pressure (12).

When the brakes are released, supply air from the secondary circuit (red) returns the spring parking brakes to an off position. Brake applications can be repeated until all the air from the secondary circuit is lost. However as the air pressure drops below 85 psi, the spring parking brakes won't return to the full off position, in fact they will start to drag. At approximately 35 psi, the spring parking brake control valve (27) on the dash will exhaust the remaining air in the secondary circuit, and the spring parking brakes are fully applied. The only way the vehicle can be moved after all air is lost is to repair the damaged circuit and recharge the system, or cage the spring parking brake system.

## Combination Tractor and Trailer with Spring Parking Brakes

The trailer system is supplied by blended tractor air taken from the primary and secondary circuits through a two-way check valve as previously described.

The system is charged by opening the trailer supply valve (28), allowing air from the tractor to pass through the tractor protection valve (24) and the trailer spring brake valve (18) directly into the trailer spring parking brake chambers (15). When air enters, the pressure protection part of the trailer spring brake valve opens, allowing the air to fill the trailer reservoirs. The trailer spring brakes will not release until the reservoir pressure on the trailer is adequate.

When a brake application is made, blended control air acts on the relay valve (17), which releases air from the trailer reservoir to the brake chambers.

In a dual air brake system, if one circuit develops a leak, the other circuit would be protected from air pressure loss by the two-way check valve (26).

If the trailer breaks away from the tractor, the control (service) and supply (emergency) lines will be pulled apart. The sudden loss of air in the supply (emergency) line will cause the trailer supply valve to close, which will cause the tractor protection valve to close, preventing air from escaping out of either broken connection. The air supply in the tractor is sealed off and is available to control the tractor brakes. At the same instant, the sudden loss of air in the supply (emergency) line causes the trailer spring parking brake valve to exhaust the air from the

trailer spring parking brake chambers, applying the trailer brakes. The trailer brakes cannot be released under these conditions unless the lines are re-coupled and the trailer reservoirs recharged.

If only the supply (emergency) line breaks between tractor and trailer, the same sequence of events will occur.

A break or rupture in the control (service) line will not affect the trailer until a brake application is made. A loss of pressure in the tractor system will then result, if pressure is allowed to drop low enough it will cause the same emergency brake application described above. However, the driver will be able to release the spring parking brakes by releasing the foot valve, rebuilding air pressure and opening the trailer supply valve.

To apply the spring parking brakes, the spring parking brake control valve (27) is closed, causing a loss of air pressure in the line which applies the spring parking brakes as described above.

The old and new tractor and trailer systems are fully interchangeable, whether they are a dual air brake system or basic air brake system, and whether they are systems with or without spring parking brakes.

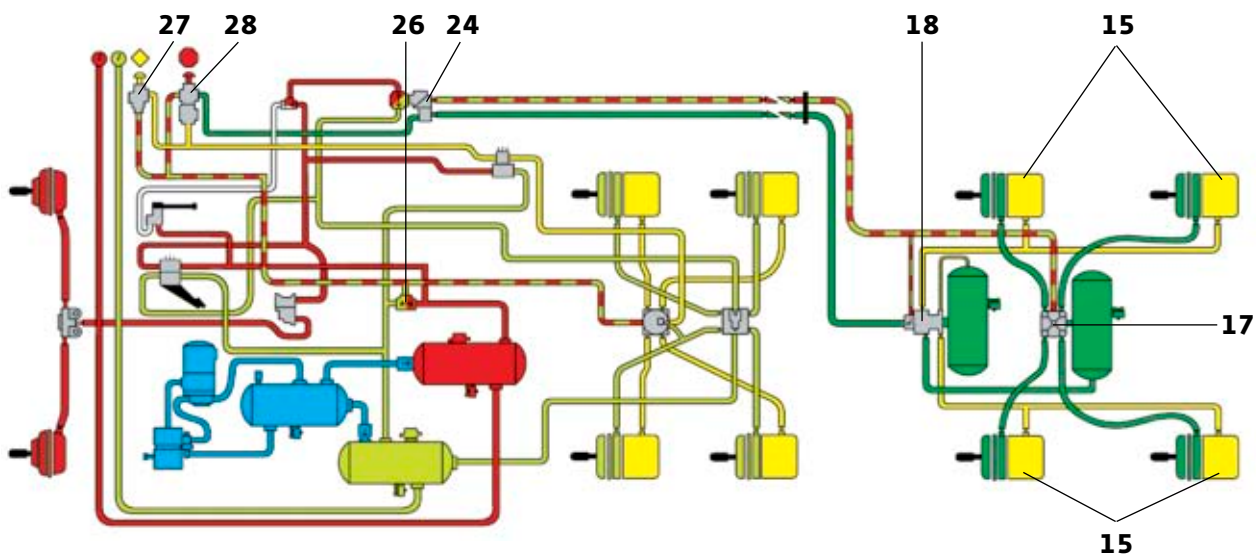

## Section Summary Questions

1. What is the basic principle of the dual air brake system?
2. What valve is used to protect the primary circuit from the secondary circuit?
3. In a dual air brake system, will the vehicle continue to have braking ability if one circuit fails?
4. Is there a difference between the foot valve used in a basic air brake system and the foot valve used in the dual air brake system?
5. Name two functions of the spring parking brakes in a dual air brake system.
6. Describe the functions of the spring brake modulator valve.
7. If the trailer breaks away from the tractor on a dual air brake system, what applies the brakes on the trailer?
8. What is blended air?
9. Can a trailer with a basic air brake system be towed by a tractor with a dual air brake system?